



US008727220B2

(12) **United States Patent**
Key

(10) **Patent No.:** **US 8,727,220 B2**
(45) **Date of Patent:** **May 20, 2014**

(54) **MACHINE READABLE INFORMATION INTERFACE FOR A CONTAINER**

(75) Inventor: **Stephen M. Key**, Modesto, CA (US)

(73) Assignee: **SpinLabel Technologies, Inc.**, Boca Raton, FL (US)

(*) Notice: Subject to any disclaimer, the term of this patent is extended or adjusted under 35 U.S.C. 154(b) by 41 days.

(21) Appl. No.: **13/436,628**

(22) Filed: **Mar. 30, 2012**

(65) **Prior Publication Data**

US 2013/0037619 A1 Feb. 14, 2013

Related U.S. Application Data

(60) Provisional application No. 61/521,048, filed on Aug. 8, 2011.

(51) **Int. Cl.**
G06K 7/10 (2006.01)

(52) **U.S. Cl.**
USPC **235/462.01; 235/462.09**

(58) **Field of Classification Search**

USPC 235/462.01, 462.08, 462.09, 486
See application file for complete search history.

(56) **References Cited**

U.S. PATENT DOCUMENTS

6,722,568 B2* 4/2004 Blanford et al. 235/462.11
8,272,562 B2* 9/2012 Ziegler 235/375
8,424,761 B2* 4/2013 Yanagi 235/383
2006/0032923 A1* 2/2006 Krupa 235/462.01
2008/0121688 A1* 5/2008 Harrop 235/375

* cited by examiner

Primary Examiner — Ahshik Kim

(74) *Attorney, Agent, or Firm* — Carr & Ferrell LLP

(57) **ABSTRACT**

The present application is directed to systems and methods for delivering information for a container. A base label may be adhered to the container, and at least a first, a second, and a third indicia displayed on the base label. A top label may cover at least a portion of the base label. The top label may be rotatable about the base label. The top label may have a transparent window allowing at least one of the first, second, or third indicia to be visible through the transparent window.

43 Claims, 17 Drawing Sheets

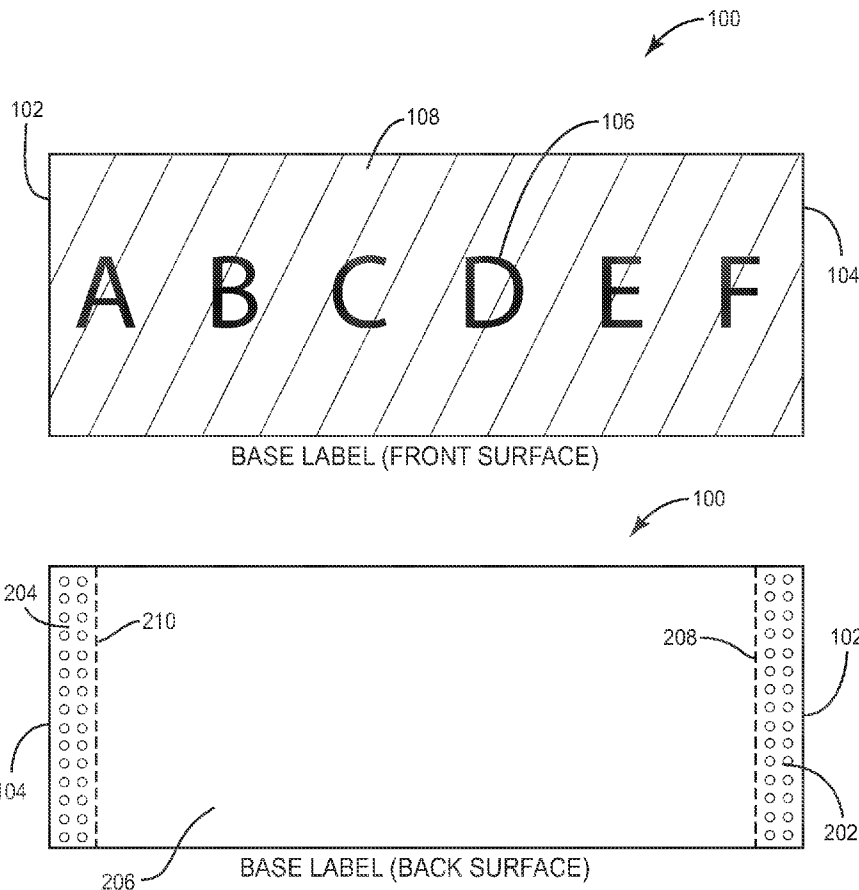

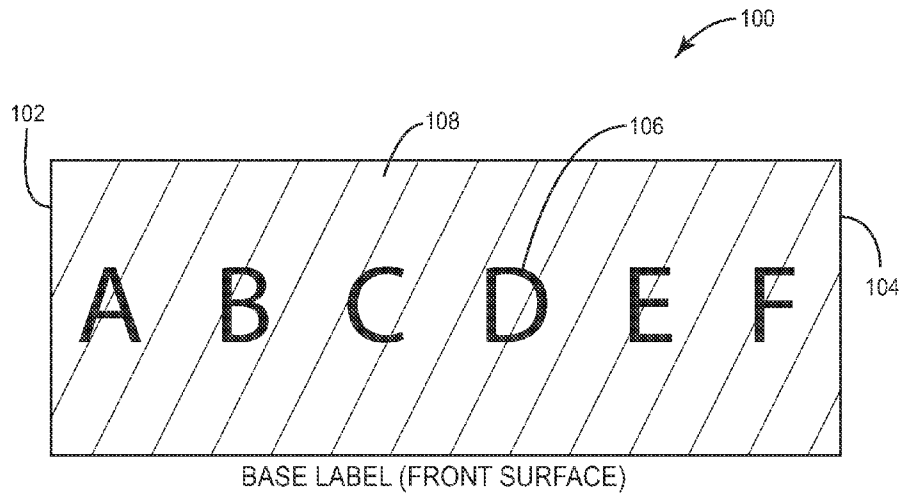

FIG. 1

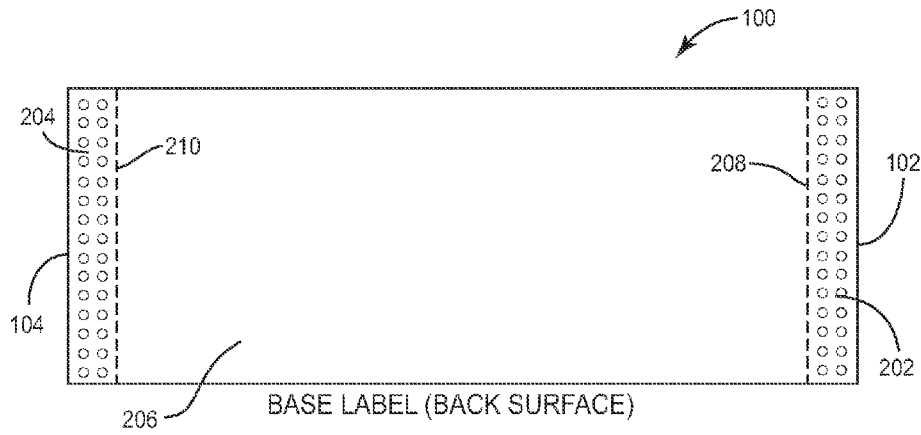

FIG. 2

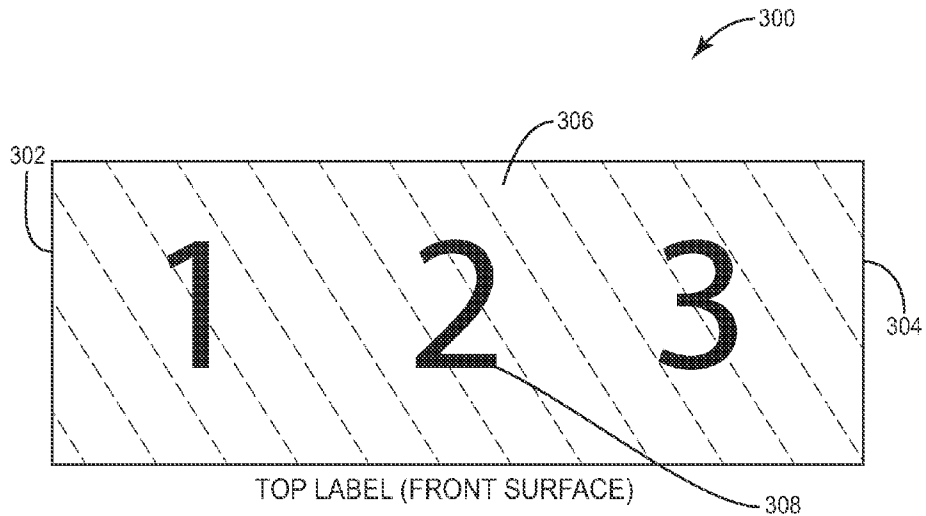

FIG. 3

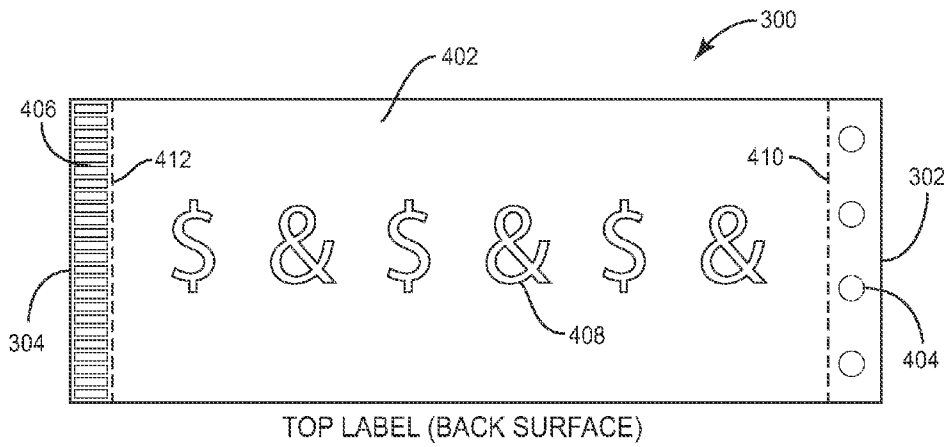

FIG. 4

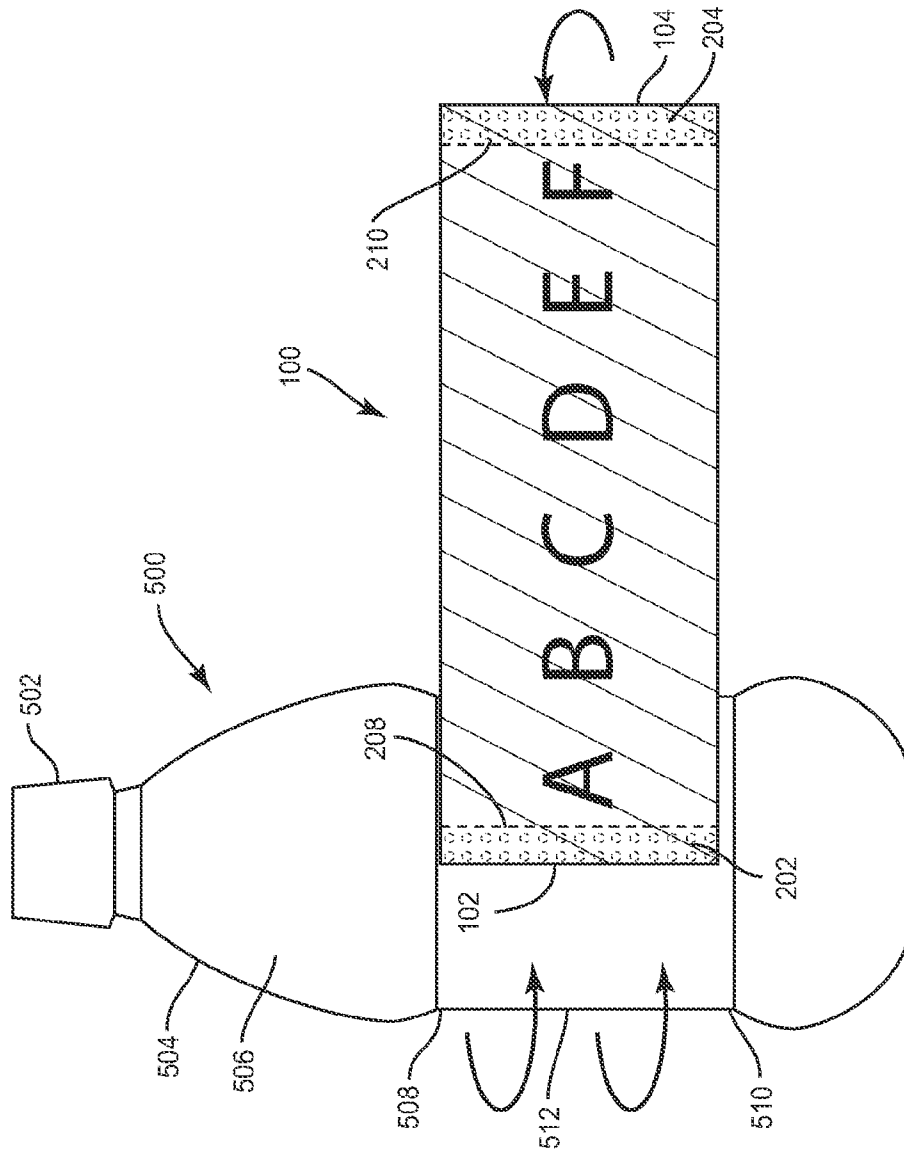

FIG. 5A

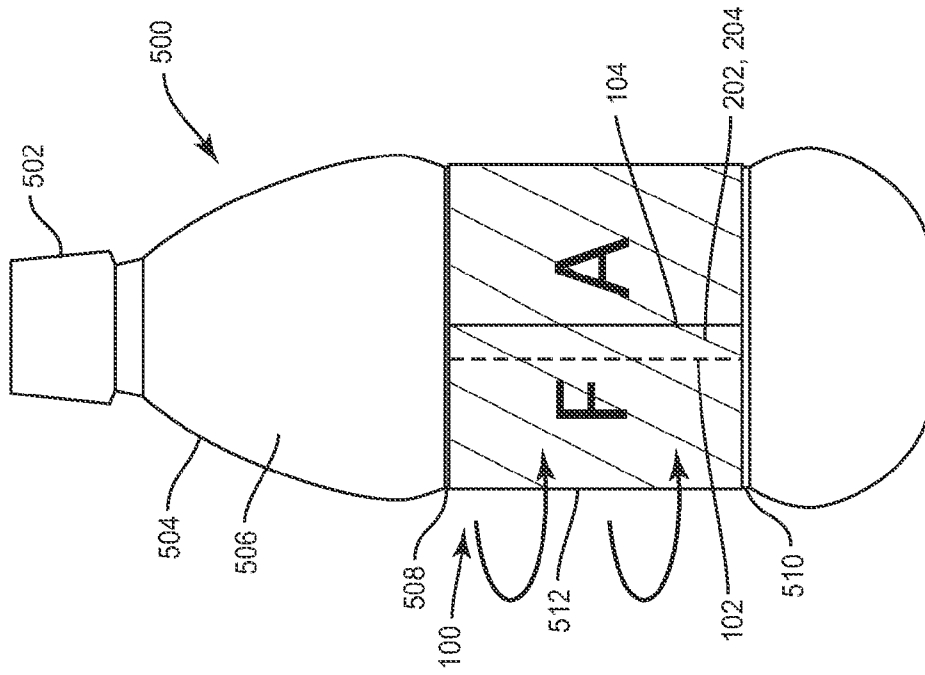

FIG. 5B

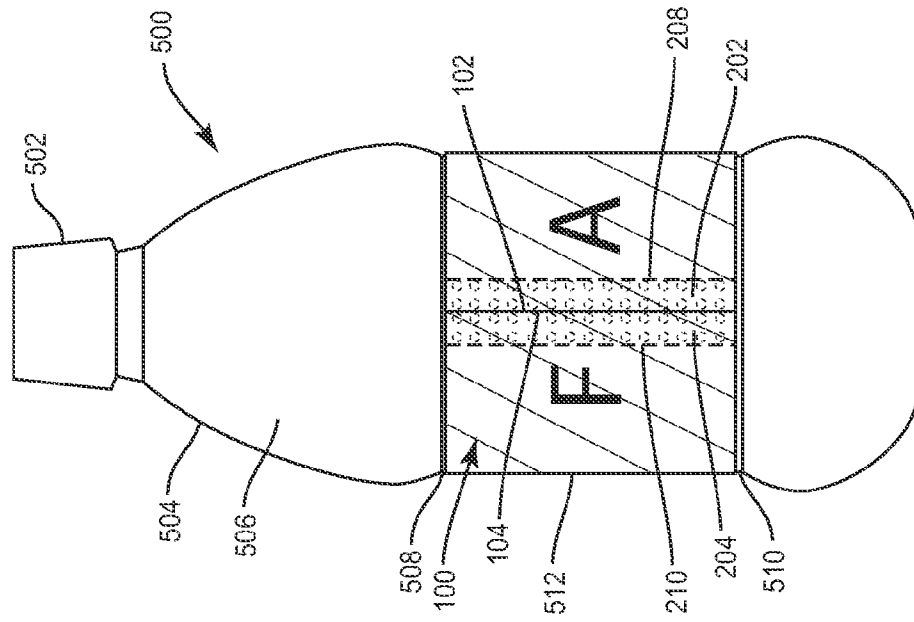

FIG. 6

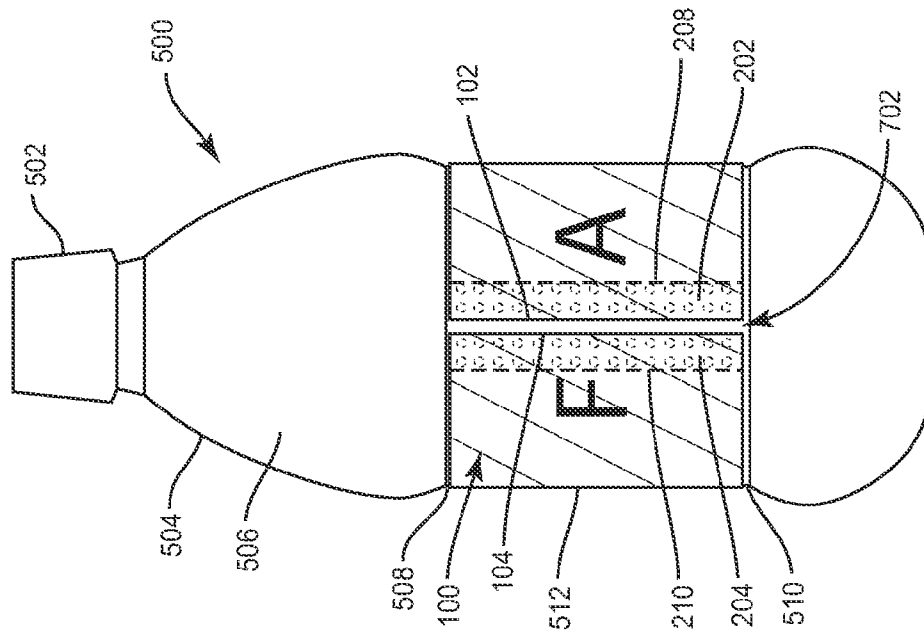

FIG. 7

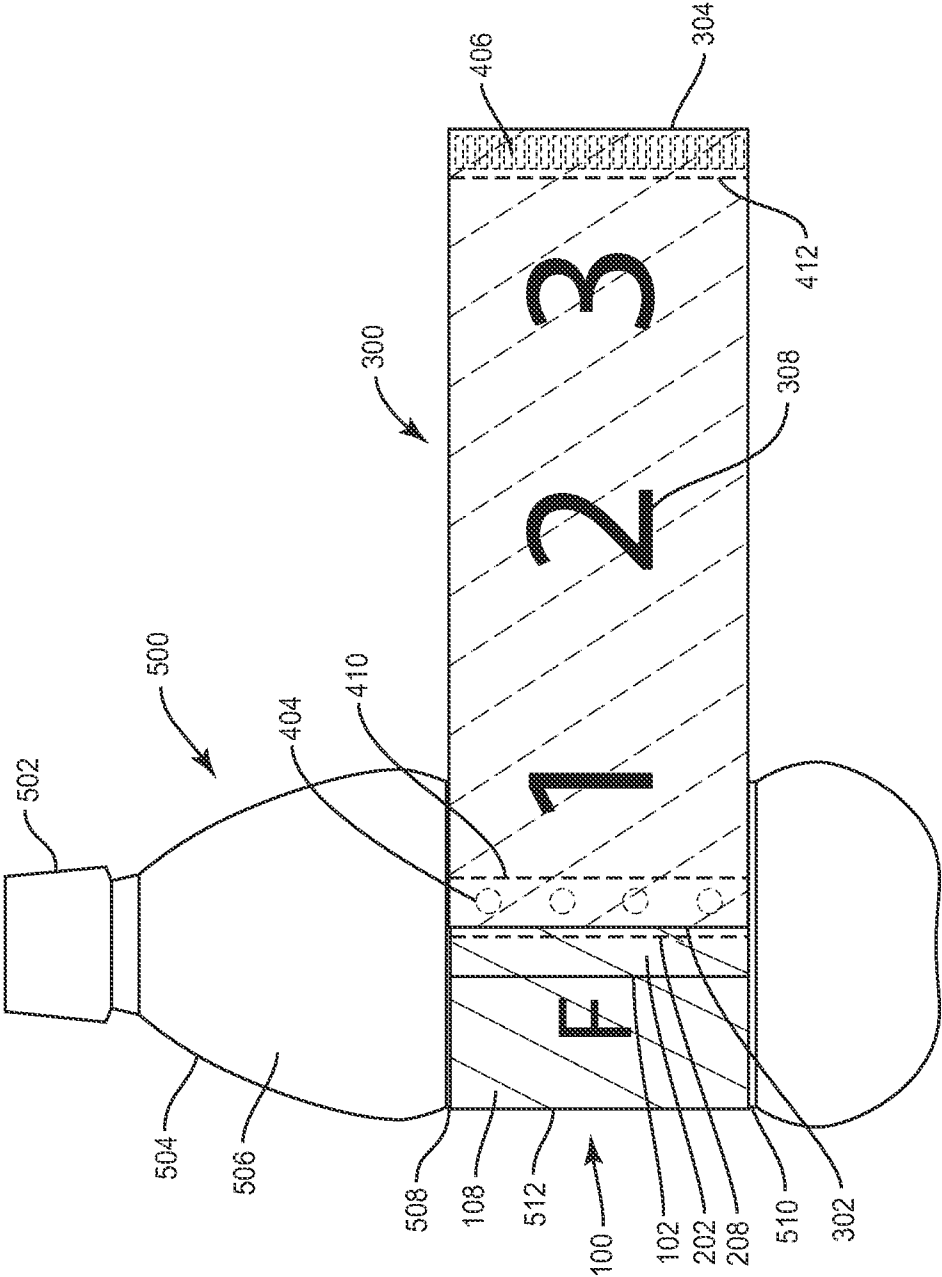

FIG. 8

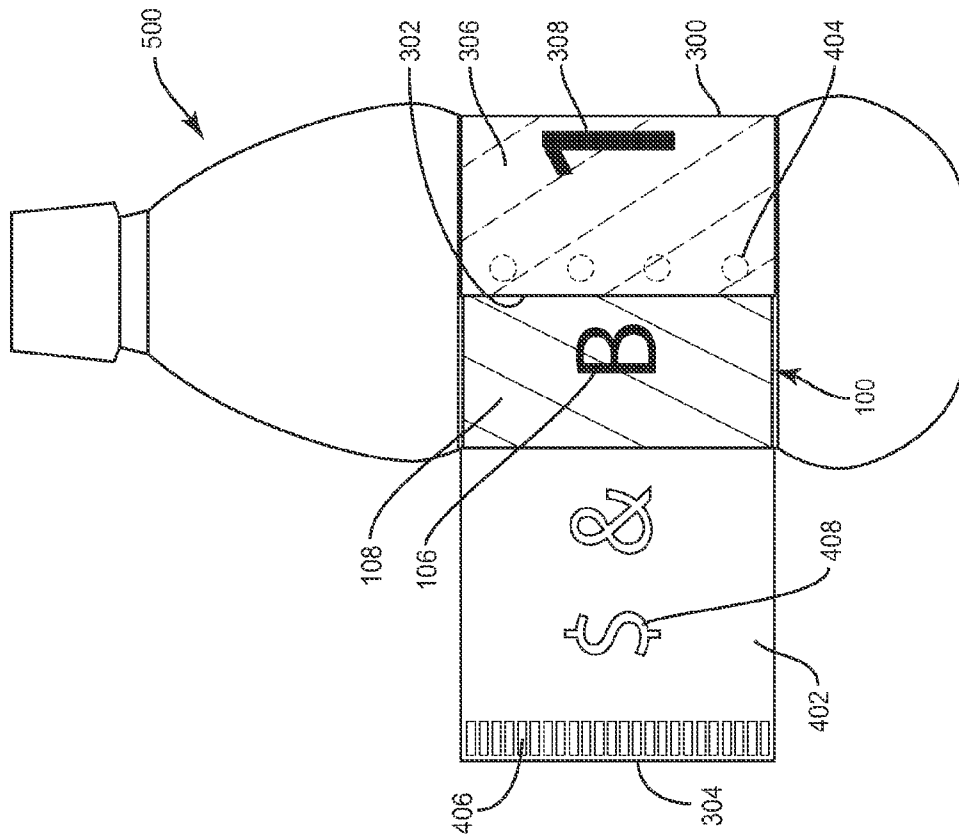

FIG. 9

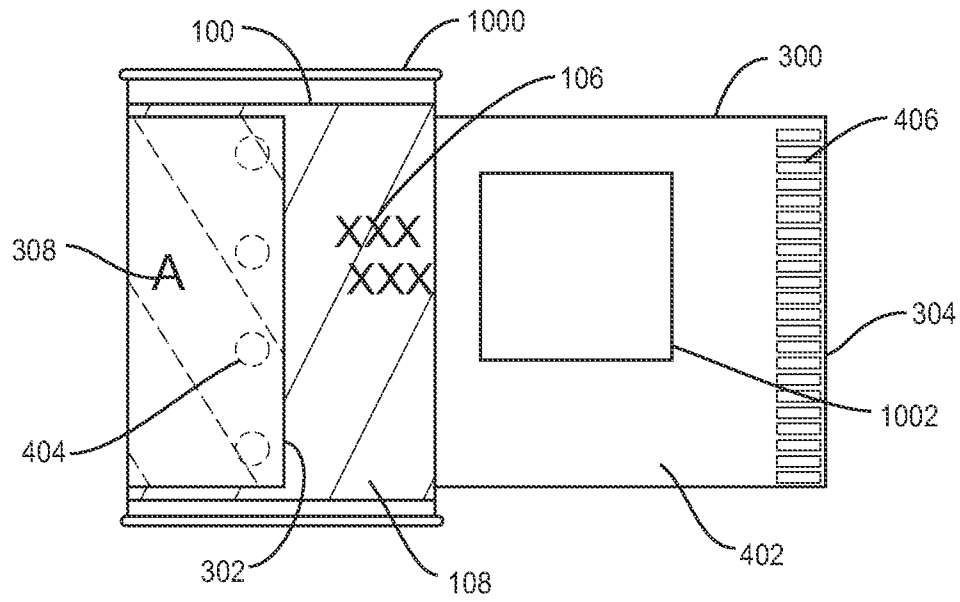

FIG. 10

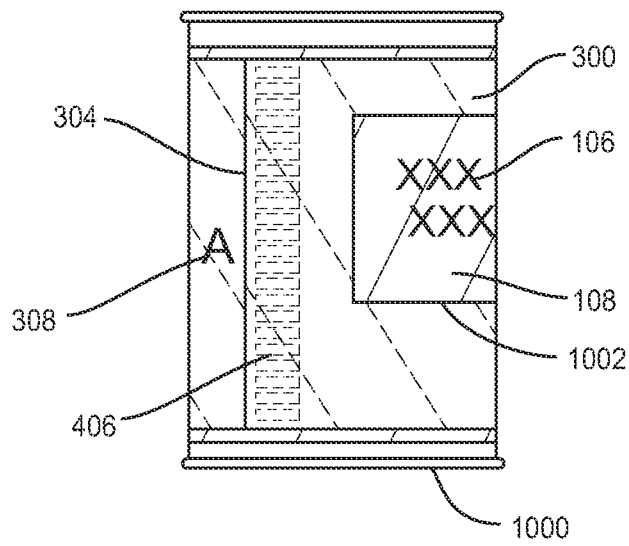

FIG. 11

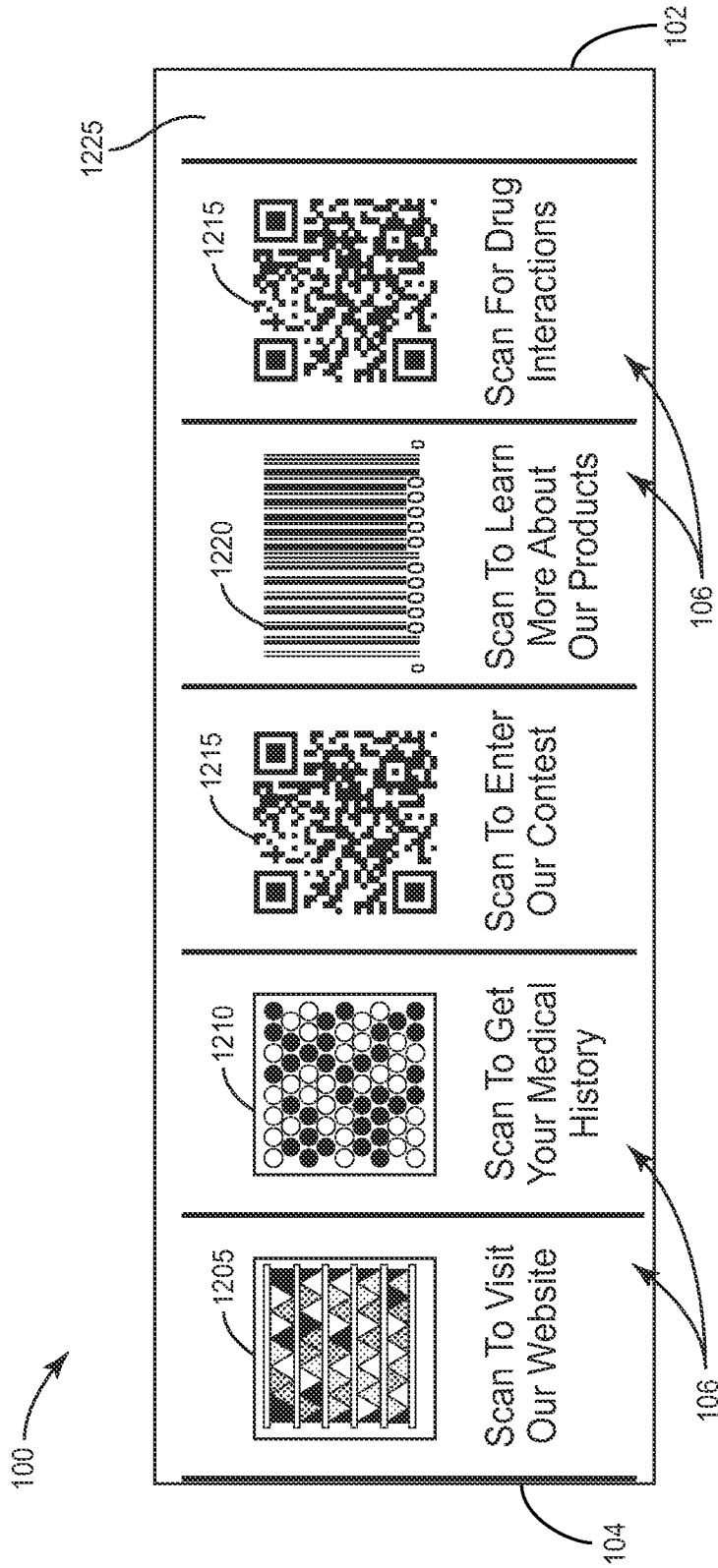

FIG. 12

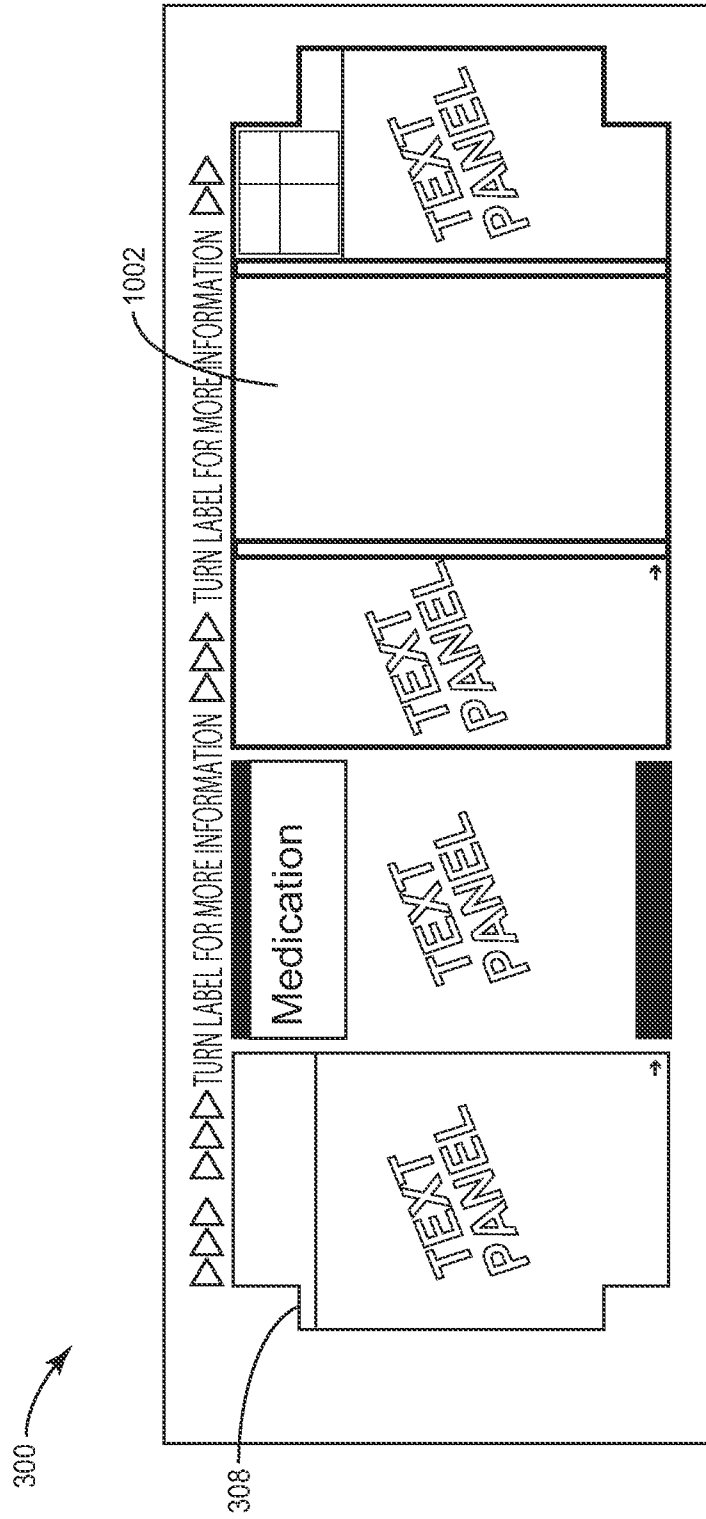

FIG. 13

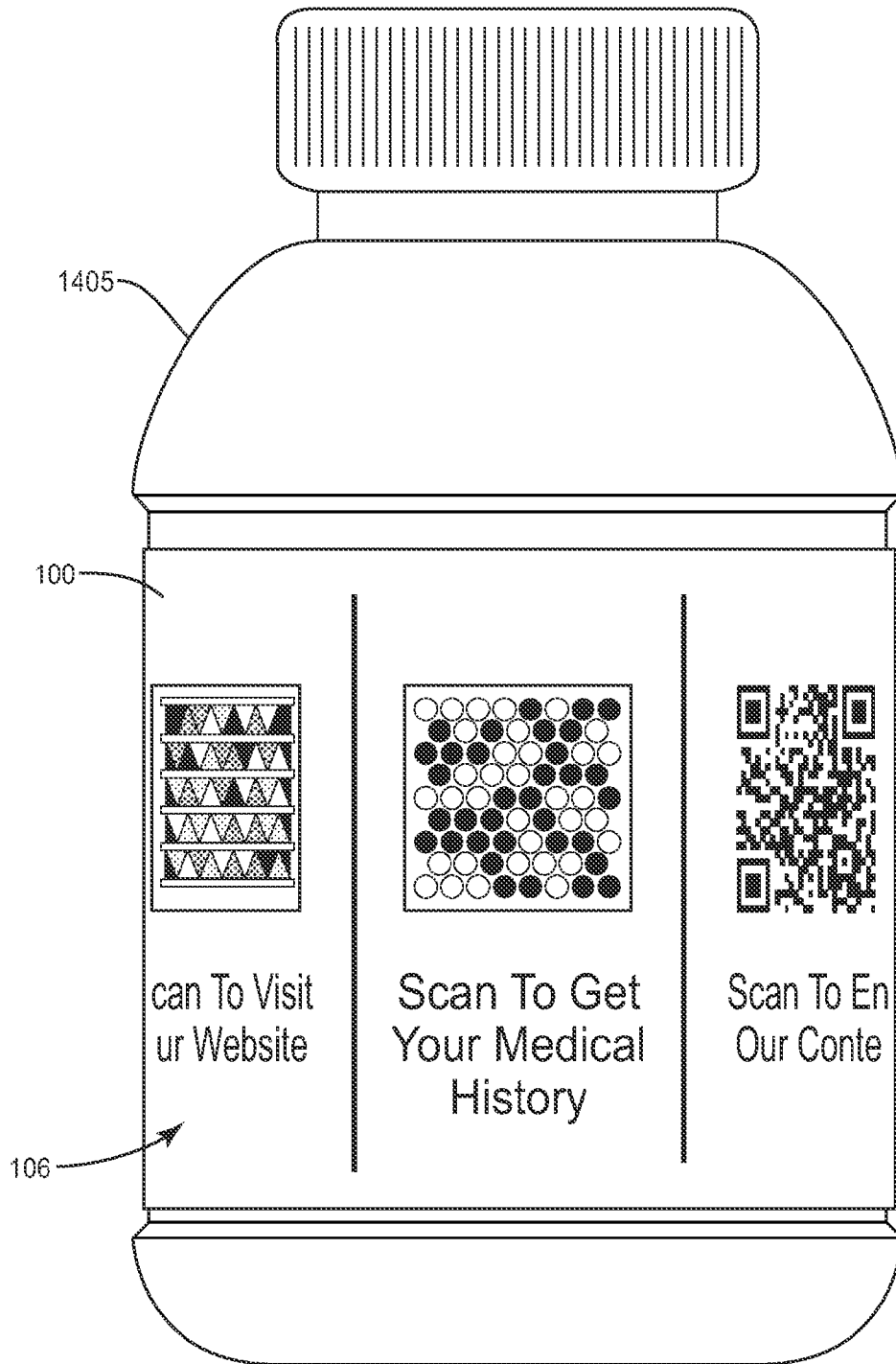

FIG. 14A

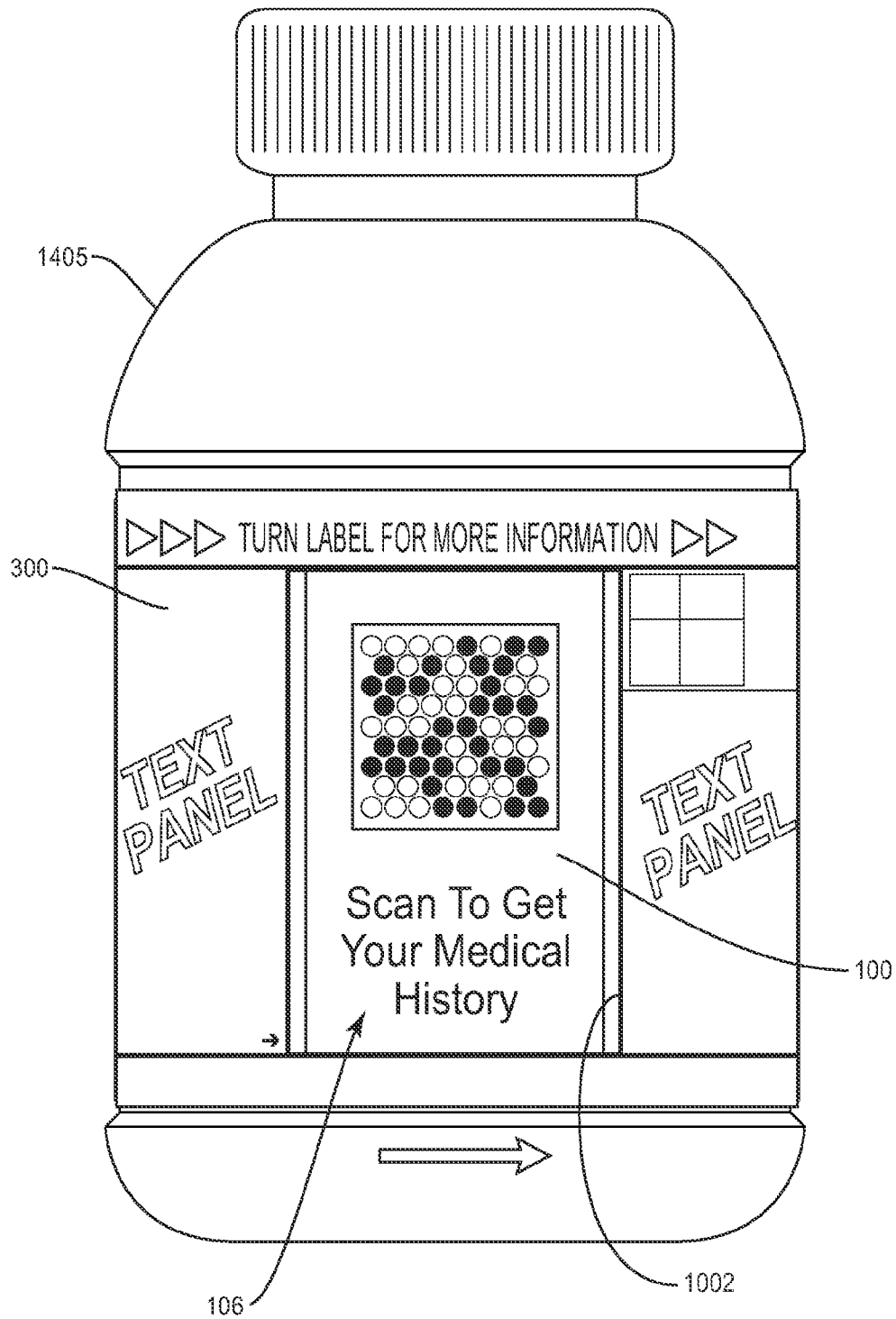

FIG. 14B

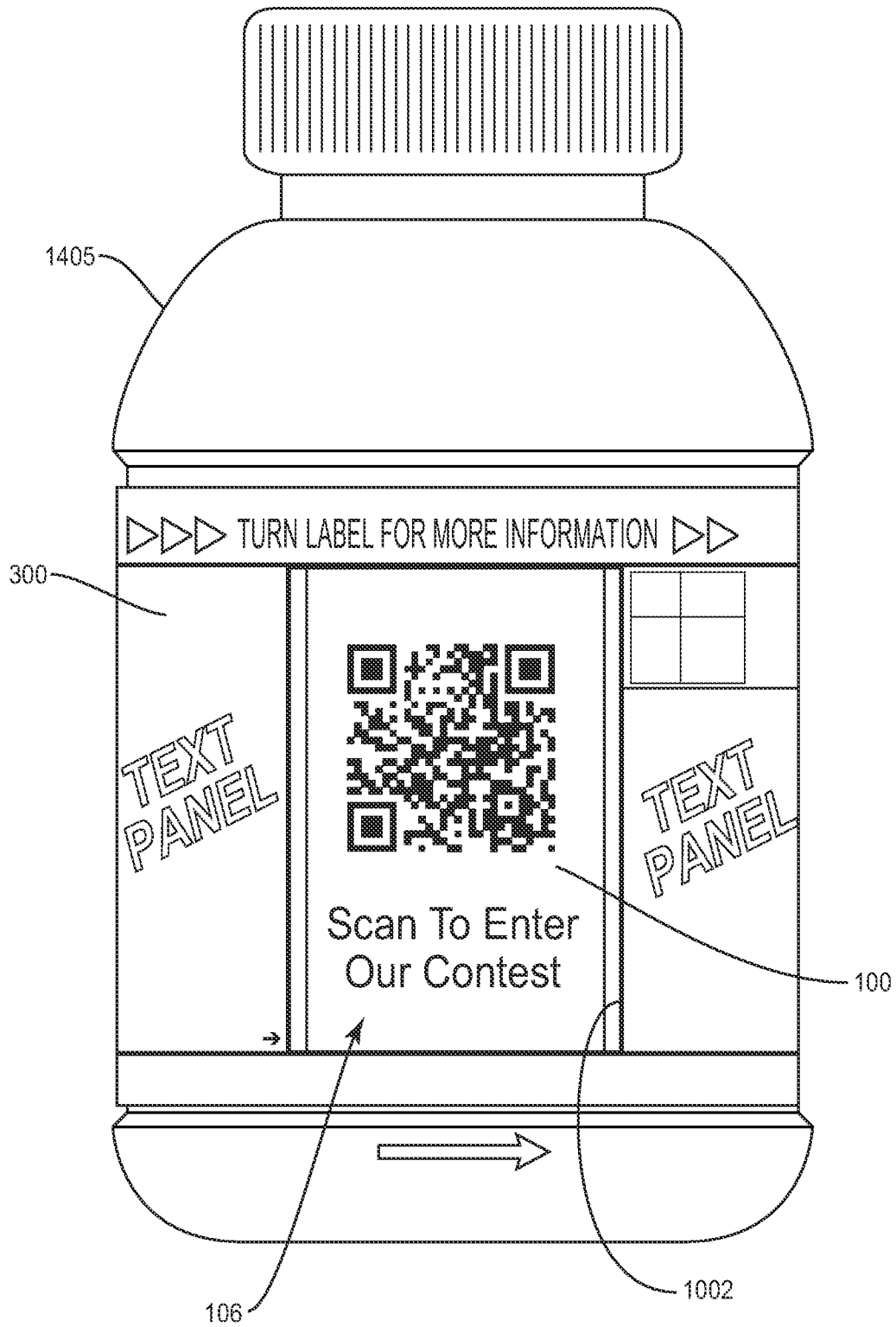

FIG. 14C

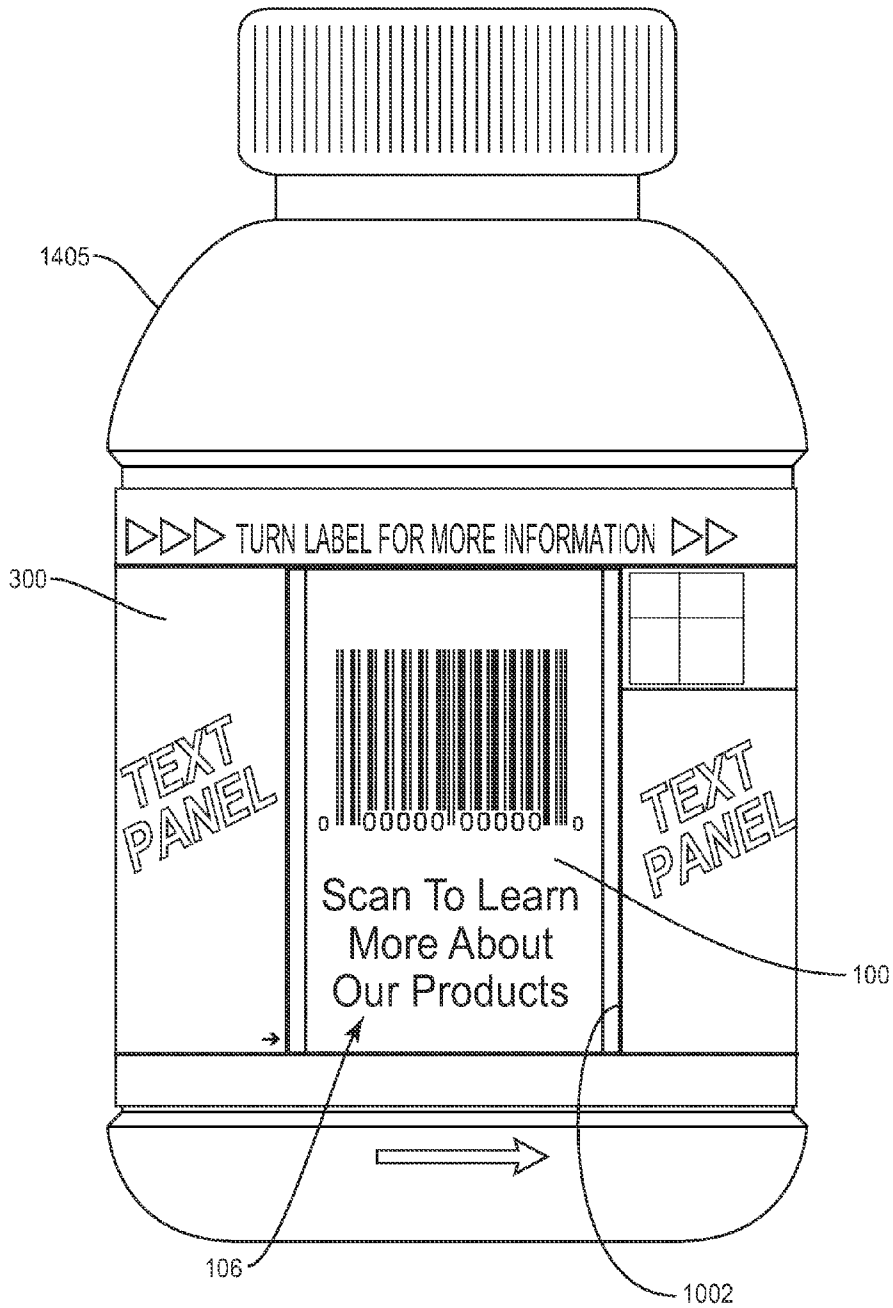

FIG. 14D

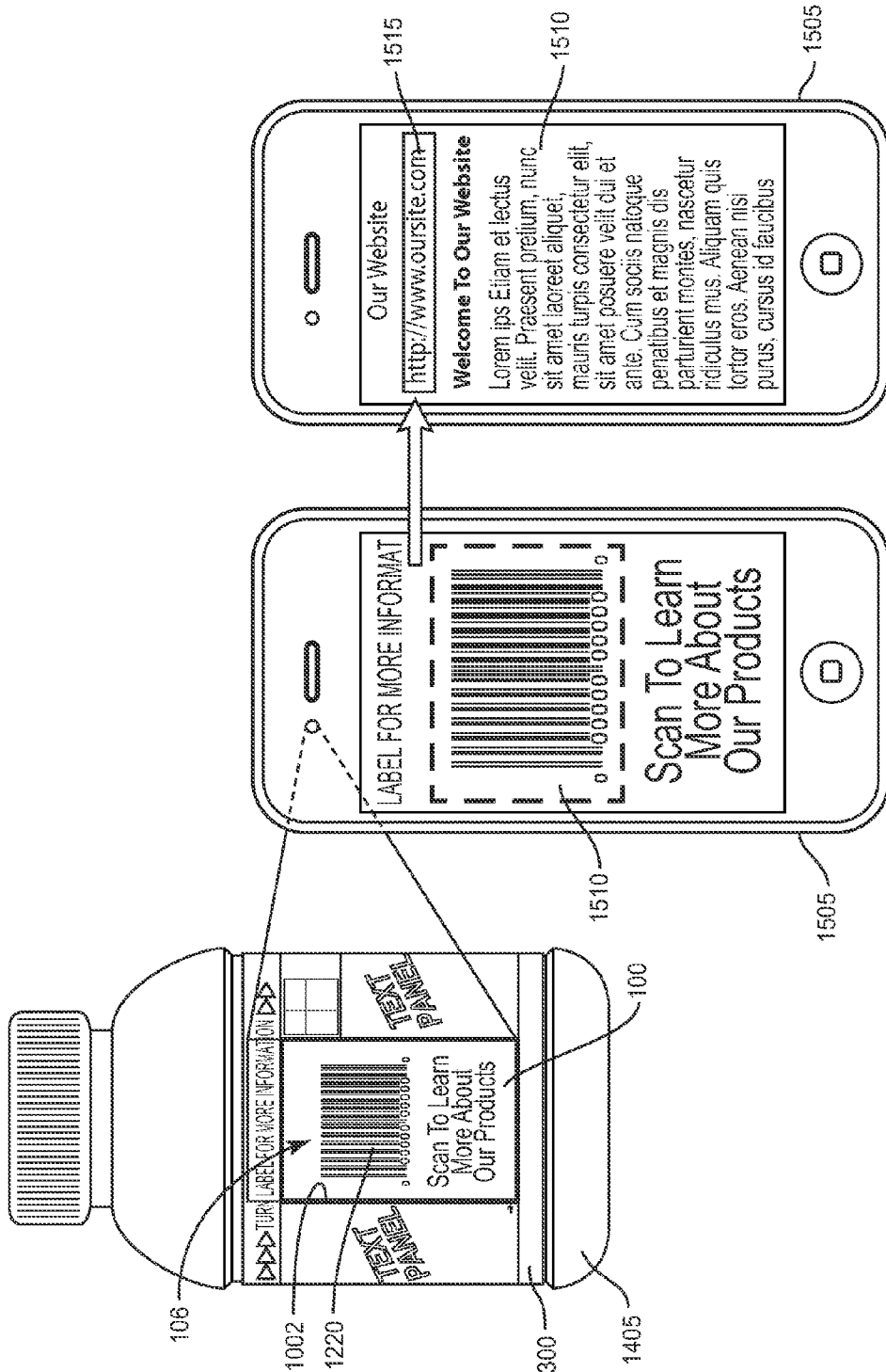

FIG. 15

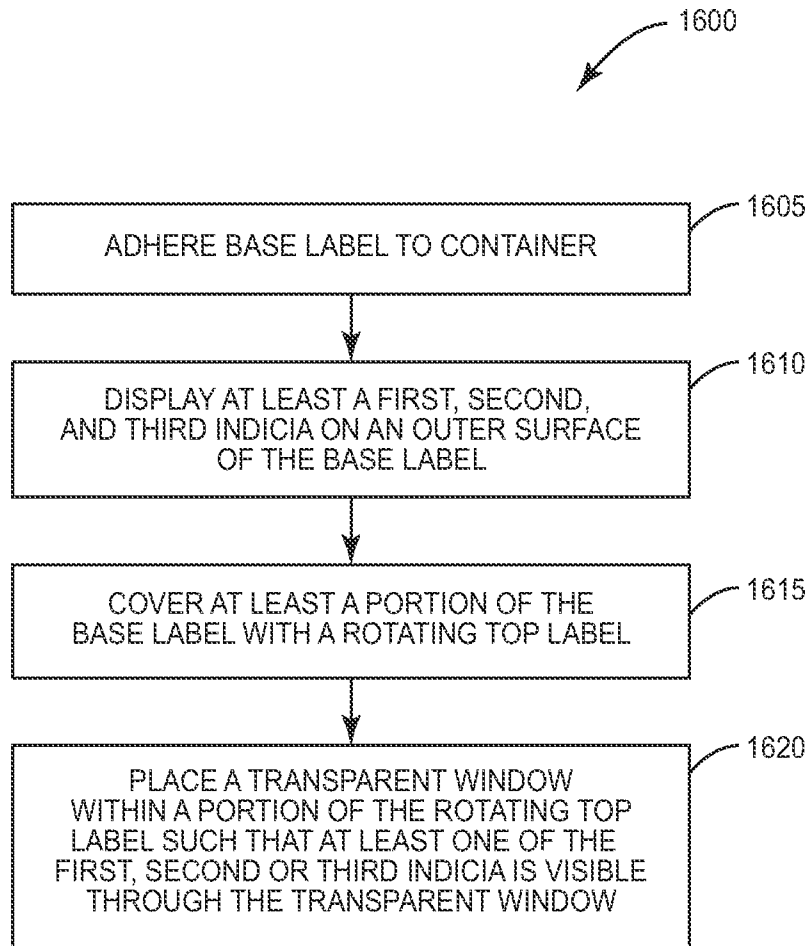

FIG. 16

1

MACHINE READABLE INFORMATION INTERFACE FOR A CONTAINER

CROSS-REFERENCE TO RELATED APPLICATIONS

The present application claims priority to provisional U.S. Patent Application Ser. No. 61/521,048, filed on Aug. 8, 2011, titled "Rotating Label Containing Bar Codes, QR Codes or Other Graphical Codes that Provide Additional Information Once Scanned by a Smart Phone," which is hereby incorporated by reference in its entirety.

FIELD OF THE INVENTION

The present application is directed generally to labels, and more specifically to labels for consumer product containers that function as an information delivery system.

BACKGROUND

Containers for consumer products have a limited amount of outer surface area for placement of labels on the container. This may pose a challenge to manufacturers of these consumer products to fit all of the information they want to deliver to the consumer, or are required by law to deliver to the consumer, in this limited area.

SUMMARY

The present application is directed to information delivery systems for a container. An exemplary information delivery system may comprise a base label adhered to the container. The base label may have a back surface and a front surface, with at least a first, a second, and a third indicia on the front surface. The information delivery system may further comprise a top label covering at least a portion of the front surface of the base label. The top label may be rotatable about the base label. In various embodiments, the top label may have a transparent window allowing at least one of the first, second, or third indicia to be visible through the transparent window.

According to additional exemplary embodiments, the present application may be directed to methods for delivering information associated with a container. An exemplary method may comprise adhering a base label having a back surface and a front surface to the container, and displaying at least a first, a second, and a third indicia on the front surface of the base label. At least a portion of the front surface of the base label may be covered by a rotating top label. A transparent window may be placed within the rotating top label, such that at least one of the first, second, or third indicia may be visible through the transparent window.

BRIEF DESCRIPTION OF THE DRAWINGS

FIG. 1 is a front view of an exemplary label according to various embodiments.

FIG. 2 is a back view of an exemplary label according to various embodiments.

FIG. 3 is a front view of an exemplary label according to various embodiments.

FIG. 4 is a back view of an exemplary label according to various embodiments.

FIG. 5A illustrates a leading edge of an exemplary label affixed to a container according to various embodiments.

FIG. 5B illustrates an exemplary label secured about a container according to various embodiments.

2

FIG. 6 illustrates an exemplary label secured about a container according to various embodiments.

FIG. 7 illustrates an exemplary base label secured about a container according to various embodiments.

FIG. 8 illustrates a leading edge of an exemplary top label affixed to an exemplary base label according to various embodiments.

FIG. 9 illustrates an exemplary top label affixed to an exemplary base label and partially wrapped about a container according to various embodiments.

FIG. 10 illustrates an exemplary top label with a window affixed to an exemplary base label and partially wrapped about a container according to various embodiments.

FIG. 11 illustrates an exemplary top label with a window secured about a container and a portion of a base label visible through the window according to various embodiments.

FIG. 12 is a front view of a base label according to various embodiments.

FIG. 13 is a front view of a top label according to various embodiments.

FIG. 14A illustrates an exemplary base label secured about a container according to various embodiments.

FIG. 14B illustrates an exemplary base label and top label secured about a container according to various embodiments.

FIG. 14C illustrates an exemplary base label and top label secured about a container according to various embodiments.

FIG. 14D illustrates an exemplary base label and top label secured about a container according to various embodiments.

FIG. 15 illustrates an electronic device scanning an indicia on the base label according to various embodiments.

FIG. 16 is an exemplary flow diagram of a method for delivering information associated with a container according to various embodiments.

DETAILED DESCRIPTION

The present application is directed to information delivery systems for a container and methods delivering information associated with a container. An exemplary information delivery system may comprise a base label adhered to the container. The base label may have a back surface and a front surface, with at least a first, a second, and a third indicia on the front surface. The information delivery system may further comprise a top label covering at least a portion of the front surface of the base label. The top label may be rotatable about the base label. In various embodiments, the top label may have a transparent window allowing at least one of the first, second, or third indicia to be visible through the transparent window.

FIG. 1 illustrates various embodiments of a front surface **108** of a base label **100** for an object, such as a medication container, according to various embodiments. The base label **100** comprises a leading edge **102** and a trailing edge **104**. While the leading edge **102** is oriented to the left and the trailing edge is oriented to the right as presented in FIG. 1, the orientation of the leading edge **102** and the trailing edge **104** could be reversed depending on which edge is first applied to the object. Both orientations are within the scope of the present disclosure. Base label front surface **108** may comprise writing or other indicia **106** thereon.

As used herein, the leading edge refers to the first edge to be affixed to the object and the trailing edge refers to the second edge to be affixed to the object or the overlapping leading edge. Depending on the orientation of the label and the object when the label is affixed to the object, either edge of the label

may be the leading edge. The orientations presented in the figures are for convenience and are not intended to be limiting in any way.

FIG. 2 illustrates various embodiments of a back surface 206 of the base label 100. In various embodiments, the base label back surface 206 comprises two strips of adhesive 202 and 204 on or immediately adjacent to the leading and trailing edges, 102 and 104, respectively. Base label leading edge adhesive 202 may have a boundary 208 defined as its limit on the base label back surface 206. Base label trailing edge adhesive 204 may also have a boundary 210. While FIG. 2 illustrates that the adhesive strips 202 and 204 are generally close to the base label leading and trailing edges 102 and 104, respectively, it is understood that the adhesive strips 202 and 204 may be continuous or discontinuous, and may extend across any portion of the base label back surface 206, including the entire base label back surface 206. In various embodiments, a length of the base label 100 may be selected to be slightly longer than a circumference of the object on which it is placed, such that the trailing edge 104 overlaps the leading edge 102, and the trailing edge 104 is affixed to the leading edge 102. In various embodiments, the length of the base label 100 may be selected to be approximately the same as the circumference of the object on which it is placed, such that the leading edge 102 and the trailing edge 104 do not overlap.

FIG. 3 illustrates various embodiments of a front surface 306 of a top label 300. Top label 300 comprises a leading edge 302 and a trailing edge 304, and indicia 308 may be imprinted on the top label front surface 306.

Various embodiments of a back surface 402 of the top label 300 are illustrated in FIG. 4. The top label back surface 402 may comprise various indicia 408 printed thereon, as well as two strips of adhesive 404 and 406 on or immediately adjacent to the leading and trailing edges, 302 and 304, respectively. Top label leading edge adhesive 404 may have a boundary 410 defined as its limit on the top label back surface 402. Top label trailing edge adhesive 406 may also have a boundary 412. While FIG. 4 illustrates that the adhesive strips 404 and 406 are generally close to the top label leading and trailing edges 302 and 304, respectively, it is understood that the adhesive strips 404 and 406 may be continuous or discontinuous, and may extend across any portion of the top label back surface 402, including the entire top label back surface 402. In various embodiments, the adhesive strips 404 and 406 are confined to areas near the leading and trailing edges 302 and 304, respectively, so as not to obscure or interfere with the top label back surface indicia 408.

The base label adhesive 202, 204 and the top label adhesive 404, 406 may be applied in a variety of patterns as can be appreciated by one skilled in the art. The adhesive 202, 204, 404, 406 may be applied in in strips, dots, droplets, circles, rectangles, squares, triangles, lines, and the like, as well as combinations of patterns.

A length of the top label 300 may be selected to be slightly longer than a circumference of the object on which it is placed, such that the top label trailing edge 304 overlaps the top label leading edge 302, and the top label trailing edge 304 is affixed to the top label leading edge 302. In various embodiments, the length of the top label 300 may be selected to be approximately the same as the circumference of the object on which it is placed, such that both the leading edge 302 and the trailing edge 304 do not overlap and are affixed to the base label front surface 108.

FIG. 5A illustrates the application of the base label 100 to an exemplary container 500 according to various embodiments. The container 500 may be a glass or plastic bottle, or other type of container such as a metal can or a cardboard

receptacle. The container may be round, rectangular, square, or any other shape known in the art. The term "container" is used here for convenience to describe exemplary embodiments. It is understood that the container may be any object, including non-containers. Container 500 may comprise a cap 502 removably secured to a body 504. Various embodiments of the body 504 may have an exterior surface 506 that comprises a upper label panel 508, a lower label panel 510, and a recessed surface 512 interposed between the upper label panel 508 and the lower label panel 510. As discussed below, the base label 100 may be applied to the container 500 at the recessed area 512 between the upper label panel 508 and the lower label panel 510.

In various embodiments, the top label 300 may be rotatable about the base label 100, as discussed below. In these embodiments, the upper label panel 508 and lower label panel 510 may function to restrict upward and downward movement of the top label 300 in relation to the container 500 such that the top label 300 generally remains in a position covering at least a portion of the base label 100.

FIG. 5B illustrates the container 500 with the base label 100 affixed to the container 500. Initially, as illustrated in FIG. 5A, base label leading edge 102 is placed in contact with the recessed surface 512 of the container 500 and affixed to the container 500 by the leading edge adhesive strip 202. With relative motion between the container 500 and the base label 100, the base label 100 may be wrapped around the container 500 with the base label trailing edge 104 now overlapping the base label leading edge 102 such that the leading edge adhesive strip 202 holds the base label leading edge 102 to the container 500 while the trailing edge adhesive strip 204 holds the base label trailing edge 104 to the overlapped base label leading edge 102.

In various embodiments as illustrated in FIG. 6, the length of the base label 100 may be substantially the same as a circumference of the recessed surface 512 of the container 500, which may allow the base label leading edge 102 and base label trailing edge 104 to abut rather than overlap. However, it is also possible that the length of the base label 100 may be shorter than the circumference of the recessed surface 512, resulting in a gap 702 between the base label leading edge 102 and the base label trailing edge 104 when the base label 100 is affixed to the recessed surface as illustrated in FIG. 7. In both of these instances, the base label trailing edge adhesive strip 204 may adhere to the recessed surface 512 of the container 500, rather than the base label leading edge 102.

In various embodiments, the base label adhesive strips 202, 204 may comprise a permanent adhesive. In general, a permanent adhesive is one that does not readily release from a surface to which it adheres after the adhesive dries or cures. Using the base label 100 as an example, the permanent adhesive 202, 204 will tend not to release from the recessed surface 512, nor will it tend to release the base label leading edge 102 or trailing edge 104 once dried or cured. In order to remove the base label from the recessed surface 512, the base label 100 may have to be torn from the adhesive, or the adhesive layer 202, 204 may have to be fractured which may leave some of the adhesive on the recessed surface 512 and some of the adhesive on the base label leading edge 102 or trailing edge 104. Once the surfaces affixed with the permanent adhesive are separated, they may not be reattached.

In FIG. 8, the base label 100 is already affixed to the recessed surface 512 of the container 500, and the application of the top label 300 over the base label 100 is illustrated according to various embodiments. The top label leading edge 302 may be placed in contact with any portion of the base label front surface 108 and affixed to the base label front

5

surface **108** by the top label leading edge adhesive strip **404**. With relative motion between the container **500** and the top label **300**, the top label **300** may be wrapped around the container **500** with the top label trailing edge **304** now overlapping the top label leading edge **302** such that the top label leading edge adhesive strip **404** holds the top label leading edge **302** to the base label **100** while the top label trailing edge adhesive strip **406** holds the top label trailing edge **304** to the overlapped top label leading edge **302**.

FIG. **9** illustrates the operation of the base label **100** and the top label **300** according to various embodiments. Beginning with the container **500** with the base label **100** and the top label **300** in place as shown, for example, in FIG. **6**, the top label trailing edge **304** may be detached from the top label leading edge **302** and at least partially peeled back as shown in FIG. **9**. The combination of the base label **100** and the top label **300** in this configuration increases the amount of surface area available for viewing by a consumer or user of the container **500**. Prior to detaching the top label trailing edge **304**, the consumer may view the top label front surface **306**. Upon detaching the top label trailing edge **304**, the consumer may now view the top label back surface **402** and the base label front surface **108** in addition to the top label front surface **306**.

One of at least three types of adhesive may be used for the top label leading edge adhesive **404**. A first type of adhesive is the permanent adhesive as described above for the base label **100**. When a permanent adhesive is used for the top label leading edge adhesive **404**, the top label leading edge generally cannot be detached without inflicting damage to one or both of the top label **300** or the base label **100**. This may be desirable for various embodiments where the top label **300** is not intended to be removed from the container **500**.

A second type of adhesive that may be used for the top label leading edge adhesive **404** is a releasable adhesive. A releasable adhesive is one that will release from a surface to which it is attached once a sufficient mechanical force is applied. A releasable adhesive may be used, for example, when the top label back surface **402** comprises a coupon for a subsequent purchase of a product. The releasable adhesive may allow the consumer to easily remove the top label **300** for later use. In various embodiments, the releasable adhesive may be a breakaway adhesive. A breakaway adhesive may have limited ability to withstand shear stresses. Shear stresses may cause the adhesive bond created between the label (e.g., top label **300**) and the surface to which it is affixed (e.g., the base label **100** or container **500**) to fail along the adhesive. In general, a releasable or breakaway adhesive may not re-attach to a surface once removed.

A third type of adhesive that may be used for the top label leading edge adhesive **404** is a resealable adhesive. A resealable adhesive may release from a surface to which it is attached once a sufficient mechanical force is applied, similar to the releasable adhesive described above. However, the resealable adhesive may be re-attached to a surface by applying pressure. A resealable adhesive may be desirable when the top label back surface **402** or the base label front surface **108** comprise information that may be needed only on occasion. Thus, the consumer or user may detach the top label **300** when the information is needed, then re-attach the top label **300**.

In various embodiments, the top label trailing edge adhesive **406** may be a releasable adhesive or a resealable adhesive, depending on the intended use of the top label **300**. As described above, if the surfaces **108**, **402** comprise information that is intended to stay with the container, the top label trailing edge adhesive **406** may be a resealable adhesive. In contrast, if the top label **300** is intended to be removed from the container **500**, a releasable adhesive may be desirable.

6

FIG. **10** illustrates various embodiments of the top label **300** comprising a window **1002**. The window **1002** may comprise a void in the top label **300** such that a portion of the base label **100** may be visible through the window. In various embodiments, the window **1002** may have a transparent covering (not shown). In various other embodiments, the window may comprise a transparent section of the top label **300** itself rather than a void. FIG. **10** illustrates the top label **300** partially wrapped about a container **1000**, and base label **100** already in place on the container **1000**. As shown, the top label leading edge adhesive **404** maintains the top label **300** coupled to the base label **100**. The top label **300** may then be moved from the position illustrated in FIG. **10** to the position illustrated in FIG. **11** to secure the top label **300** about the container **1000**. Top label trailing edge adhesive **406** may couple to the top label leading edge **302** and trailing edge **304** overlap; otherwise, the top label trailing edge adhesive **406** may be coupled to the base label front surface **108**.

Once the top label **300** is in position on the container **1000** as illustrated in FIG. **11**, at least a portion of the base label front surface indicia **106** may be visible through the window **1002**. This may allow viewing of a first portion of the base label **100** without removing the top label **300**. In various embodiments, the top label leading edge adhesive **404** may be a breakaway adhesive. Rotation of the top label **300** relative to the base label **100** may exert shear stresses on the breakaway adhesive, causing the adhesive bond affixing the top label leading edge **302** to the base label **100** to fail. The top label **300** may then be freely rotatable about the base label **100**, and a second portion of the base label **100** may be visible when the top label **300** is rotated to a second position. The window **1002** may be rectangular as illustrated in FIGS. **10** and **11**, or any other shape as needed for a particular application. For example, the window **1002** may be a slit that reveals an alphanumeric string on the base label **100**. In various embodiments, the top label **300** may comprise more than one window **1002**. Various embodiments in which the top label trailing edge adhesive **406** is a resealable or releasable adhesive may allow the top label **300** to be peeled back to reveal the top label back surface **402** and essentially the entire base label front surface **108** or to be removed from the container **1000**, in addition to being rotatable.

One skilled in the art will readily recognize that labels may be applied to containers using a variety of methods and that there may be a variety of single-label and multi-label systems other than those described above. Any such application methods or label systems may be used with the present disclosure. The above descriptions are exemplary and not to be construed as limiting in any way. Examples of other application methods and label systems may be disclosed in U.S. Pat. Nos. 5,884,421, 6,086,697, 6,237,269, 6,402,872, 6,631,578, 6,649,007, 7,087,298, and 7,172,668.

FIGS. **12** and **13** illustrate a base label **100** and top label **300**, respectively, that may comprise an information delivery system for a container **1405** (see FIG. **14**) according to various embodiments. The base label indicia **106** may comprise a plurality of individual machine readable indicia **1205-1220**. The top label **300** may comprise indicia **308** relaying product-related information, safety-related information, manufacturer-related information, and the like. In various embodiments, the top label may contain a transparent window **1002** as described previously (see FIG. **10**).

The various embodiments of the base label **100** as illustrated in FIG. **12** may comprise a blank portion **1225** along the leading edge **102** that is essentially void of any base label indicia **106**. As described previously, the trailing edge **104**

may overlap the leading edge **102** when the base label **100** is applied to the container **1405**. The blank portion **1225** may provide a space for attachment of the trailing edge without obscuring any of the base label indicia **106**.

In various embodiments, the machine readable indicia **1205-1220** may comprise any linear, 2-dimensional, or 3-dimensional indicia or code as known in the art that may be machine readable to cause an electronic device to execute a function when the machine readable indicia **1205-1220** is scanned by the electronic device. For example, the machine readable indicia **1205-1220** may comprise a High Capacity Color Barcode (HCCB) comprising a plurality of barcode shapes in combination with a plurality of colors per symbol. The machine readable indicia **1205** is comprised of triangular shapes, while the machine readable indicia **1210** is a HCCB code is comprised of circular shapes. According to various embodiments, the base label indicia **106** may also comprise a Quick Response (QR) Code **1215** or a linear barcode **1220**.

In addition to the machine readable indicia **1205-1220** illustrated in FIG. **12**, other indicia, codes, or symbols, whether linear, 2-dimensional, 3-dimensional, color, or monochrome, as are known in the art may also be used in various embodiments. For example, the base label indicia **106** may comprise any or any combination of:

3-DI, a 2-dimensional matrix of circular symbols;

ArrayTag, a 2-dimensional matrix of groups of hexagonal symbols;

Aztec Code, a 2-dimensional square matrix of square symbols;

Codablock, a 2-dimensional array of stacked linear codes; Code 1, a 2-dimensional matrix of horizontal and vertical bars;

Code 16K, a 2-dimensional array of stacked linear codes;

Code 49, a 2-dimensional array of stacked linear codes;

ColorCode, a 2-dimensional color matrix of square symbols;

CP Code, a 2-dimensional square matrix of square symbols;

DataGlyphs, a 2-dimensional matrix of “/” and “\” marks;

Data Matrix, a 2-dimensional square matrix of square symbols;

Datastrip Code, a 2-dimensional matrix of square symbols;

Dot Code A, a 2-dimensional square matrix of dots;

hueCode, a 2-dimensional matrix of blocks of cells in varying shades of gray;

MaxiCode, a 2-dimensional square matrix of interlocking hexagonal symbols;

MiniCode, a 2-dimensional square matrix of square symbols;

PDF 417, a 2-dimensional matrix of a combination of linear barcodes and square symbols;

Snowflake Code, a 2-dimensional square matrix of dots;

SuperCode, a 2-dimensional matrix of a combination of linear barcodes and square symbols;

Ultracode, a color or monochrome 2-dimensional array matrix of variable length strips of pixel columns; and 3D Barcode, an embossed linear barcode of lines of varying height.

The base label indicia **106** described above represent a sampling of exemplary machine readable indicia currently available and are not to be construed as limiting in any manner. Other linear, 2-dimensional, and 3-dimensional codes, currently known or developed in the future, are within the scope of the present disclosure. Additionally, the base label indicia **106** may comprise any combination of machine readable indicia, as well as non-machine readable indicia.

FIGS. **14A-14D** illustrate the base label **100** and top label **300** on a medicine container **1405** according to various embodiments. The base label **100** and the top label **300** may comprise an information delivery system that may be used, for example, on the medication container **1405** to provide additional functionality that may allow a consumer to obtain a wide variety of additional information about the product in the container **1405**, the company that produced the product, medical history of the consumer, drug facts, drug interactions, games, contests, information on related products or services, or any other information. In FIG. **14A**, the base label **100** is positioned on the container **1405**, and the base label **100** may comprise a plurality of base label indicia **106** (all of a portion of which may be machine readable). FIG. **14B** illustrates the top label **300** in place over the base label **100**. As described previously, the top label **300** may be applied such that the top label **300** is rotatable around a circumference of the container **1405**. In FIG. **14B**, the top label **300** has been rotated in the direction of the arrow revealing at least one of the base label indicia **106** through the transparent window **1002** in the top label **300**. Similarly,

FIGS. **14C** and **14D** illustrate the top label **300** further rotated in the direction of the arrow, thus revealing a different base label indicia **106** through the transparent window **1002** of the top label **300**. Although FIGS. **14B-14D** illustrate a single base label indicia **106** visible through the transparent window **1002**, two or more base label indicia **106** may simultaneously be visible through the transparent window **1002** in various embodiments.

The top label **300** may comprise a dual ply (or multi-ply) construction in which a ply in contact with the base label **100** is a material selected for low sliding friction characteristics. The low sliding friction characteristics may enhance the ease of rotating and sliding the top label **300** about the base label **100**. In various embodiments, the top label **300** ply in contact with the base label **100** may be coated with a substance to impart the low sliding friction characteristics.

As described previously, the base label indicia **106** may comprise codes or symbols that are machine readable. According to various embodiments as illustrated in FIG. **15**, the consumer may use any electronic device, such as a smartphone **1505**, to read or scan the base label indicia **106**. The smartphone **1505** may comprise an application that enables a reading or scanning function on the smartphone **1505**. Once the smartphone **1505** (or other electronic device such as a tablet computer or scanner coupled to a computer) reads or scans the base label indicia **106**, the base label indicia **106** may be configured to cause the smartphone **1505** to execute a function. In the embodiment of FIG. **15**, the function executed by the smartphone **1505** may be to open a web browser program and direct the browser to a pre-designated website.

In the example of FIG. **15**, the base label indicia **106** comprises the barcode **1220** and additional text indicating that information about additional products may be obtained by scanning the barcode **1220**. Thus, in this embodiment the consumer has scanned the barcode **1220**, and the barcode **1220** has caused the smartphone **1505** to open the web browser and directed the web browser to a pre-determined website corresponding to the additional products.

As readily recognized by one skilled in the art, the function executed by the smartphone **1505** may be any function capable of being executed on an electronic computing device. For example, the function may be to display product information, or display a scannable coupon on the smartphone **1505** that the consumer may redeem at a store or online. The product information and the scannable coupon may be related

to the product in the container **1405**, or some other product or service. In various embodiments, the function may cause the smartphone **1505** to download an application onto the smartphone **1505**, or cause an application to run or execute an application, such as launching an interactive game on the smartphone **1505**. In various embodiments, the function executed may be to display medical information on the smartphone **1505**, such as a medical history of the consumer, potential drug interactions, overdose information, and the like. Where the product in the container **1405** is a food ingredient, the function executed may be to display one or more recipes on the smartphone **1505** that call for the food ingredient. In still other embodiments, the function executed may cause the smartphone **1505** to take a photograph of the base label indicia **106**. In some embodiments, the function executed may be to automatically register the consumer in a contest, or register the consumer to receive periodic updates about products or services.

FIG. **16** illustrates a general flow chart of various embodiments of a method **1600** for delivering information associated with a container. A base label **100** may be applied to a container **1405** (step **1605**). The base label **100** may have a back surface **206** and a front surface **108**. At least a first, a second, and a third indicia **106** may be displayed on the front surface **108** of the base label **100** (step **1610**). Each of the first, second, and third indicia **106** may comprise a linear, 2-dimensional, or 3-dimensional machine readable indicia. At step **1615**, at least a portion of the base label **100** may be covered with a rotating top label **300**. In various embodiments, the base label **100** may be coupled to the container **1405** while the top label **300** is free to rotate about the base label **100**. A transparent window **1002** may be placed within a portion of the rotating top label **300** at step **1620** such that at least one of the first, second, or third indicia **106** is visible through the transparent window **1002**. As the top label **300** is rotated about the base label **100**, the first, second, and third indicia **106** may alternately be visible through the transparent window **1002**. In various embodiments, more than one of the indicia **106** may be visible through the transparent window **1002**. For example, the first and second indicia **106** may simultaneously be visible through the transparent window **1002**, or the second and third indicia **106** may simultaneously be visible through the transparent window **1002**. In various other embodiments, the top label **300** may comprise multiple windows **1002** such that multiple indicia **106** may be visible simultaneously through the multiple windows **1002**.

In various embodiments, the indicia **106** may be imprinted, embossed, or molded directly on an outer surface of the container **1405** in place of all or a portion of the base label **100**. The imprinting or embossing may be carried out using any printing or image transfer method known in the art. In various embodiments, the printing or image transfer method may be an offset process in which an image is transferred from a plate to an intermediate carrier, then to the outer surface of the container **1405**. The offset process may also involve lithographic techniques. Other printing or image transfer methods may comprise, for example, flexography, pad printing, relief printing, rotogravure, screen printing, and electrophotography. According to various embodiments, the indicia **106** may be digitally printed on the outer surface of the container **1405** using, for example, inkjet printing or laser printing. Chemical printing technologies, such as blueprint or diazo print may also be used in various embodiments.

Spatially relative terms such as “under”, “below”, “lower”, “over”, “upper”, and the like, are used for ease of description to explain the positioning of one element relative to a second element. These terms are intended to encompass different

orientations of the device in addition to different orientations than those depicted in the figures. Further, terms such as “first”, “second”, and the like, are also used to describe various elements, regions, sections, etc. and are also not intended to be limiting. Like terms refer to like elements throughout the description.

As used herein, the terms “having”, “containing”, “including”, “comprising”, and the like are open ended terms that indicate the presence of stated elements or features, but do not preclude additional elements or features. The articles “a”, “an” and “the” are intended to include the plural as well as the singular, unless the context clearly indicates otherwise.

The present invention may be carried out in other specific ways than those herein set forth without departing from the scope and essential characteristics of the invention. The present embodiments are, therefore, to be considered in all respects as illustrative and not restrictive, and all changes coming within the meaning and equivalency range of the appended claims are intended to be embraced therein.

What is claimed is:

1. An information delivery system for a container, the system comprising:
 - a base label adhered to the container, the base label having a back surface and a front surface;
 - at least a first, a second, and a third indicia on the front surface of the base label;
 - a rotating top label covering at least a portion of the front surface of the base label; and
 - a transparent window within a portion of the rotating top label, the transparent window allowing at least one of the first, the second, or the third indicia to be visible through the transparent window.
2. The system of claim 1, wherein the transparent window allows at least two of the first, the second, and the third indicia to be visible through the transparent window.
3. The system of claim 1, wherein at least one of the indicia is a machine readable indicia.
4. The system of claim 1, wherein at least one of the indicia is a bar code.
5. The system of claim 1, wherein at least one of the indicia is a quick response code.
6. The system of claim 3, further comprising an electronic device wherein the machine readable indicia is configured to cause the electronic device to execute a function when the machine readable indicia is scanned by the electronic device.
7. The system of claim 6, wherein the function is a display of a website on the electronic device.
8. The system of claim 6, wherein the function is a display of a scannable coupon on the electronic device.
9. The system of claim 6, wherein the function is a downloading of an application onto the electronic device.
10. The system of claim 6, wherein the function is a display of patient medical history or drug interaction information.
11. The system of claim 6, wherein the function is an automatic registration in a contest.
12. The system of claim 6, wherein the function is a launching of an interactive game on the electronic device.
13. The system of claim 4 further comprising an electronic device wherein the bar code is configured to cause the electronic device to execute a function when the bar code is photographed by the electronic device.
14. The system of claim 5, wherein the quick response code is configured to cause an electronic device to execute a function when the quick response code is photographed by the electronic device.
15. The system of claim 6, wherein the function is a display of product information.

11

16. The system of claim 15, wherein the product information includes promotional information about a related product.

17. The system of claim 15, wherein the product information includes a recipe for a product having the machine readable indicia scanned by the electronic device.

18. A method for delivering information associated with a container, the method comprising:

adhering a base label to the container, the base label having a back surface and a front surface;

displaying at least a first, a second, and a third indicia front surface of the base label;

covering at least a portion of the front surface of the base label with a rotating top label; and

placing a transparent window within a portion of the rotating top label, the transparent window allowing at least one of the first, second, or third indicia to be visible through the transparent window.

19. The method of claim 18, wherein the transparent window allows at least two of the first, second, and third indicia to be visible through the transparent window.

20. The method of claim 18, wherein at least one of the indicia is a machine readable indicia.

21. The method of claim 18, wherein at least one of the indicia is a bar code.

22. The method of claim 18, wherein at least one of the indicia is a quick response code.

23. The method of claim 20, further comprising an electronic device wherein the machine readable indicia is configured to cause the electronic device to execute a function when the machine readable indicia is scanned by the electronic device.

24. The method of claim 23, wherein the function is a display of a website on the electronic device.

25. The method of claim 23, wherein the function is a display of a scannable coupon on the electronic device.

26. The method of claim 23, wherein the function is a downloading of an application onto the electronic device.

27. The method of claim 23, wherein the function is a display of patient medical history or drug interaction information.

28. The method of claim 23, wherein the function is an automatic registration in a contest.

29. The method of claim 23, wherein the function is a launching of an interactive game on the electronic device.

30. The method of claim 21, further comprising an electronic device wherein the bar code is configured to cause the

12

electronic device to execute a function when the bar code is photographed by the electronic device.

31. The method of claim 22 wherein the quick response code is configured to cause an electronic device to execute a function when the quick response code is photographed by the electronic device.

32. The method of claim 23, wherein the function is a display of product information.

33. The method of claim 32, wherein the product information includes promotional information about a related product.

34. The method of claim 32, wherein the product information includes a recipe for a product having a quick response code scanned by the electronic device.

35. An information delivery system for a container, the system comprising:

at least a first, a second, and a third indicia on an outer surface of the container;

a rotating label covering at least a portion of the outer surface of the container; and

a transparent window within a portion of the rotating label, the transparent window allowing at least one of the first, second, or third indicia to be visible through the transparent window.

36. The system of claim 35, wherein at least one of the indicia is imprinted on the outer surface of the container.

37. The system of claim 35, wherein at least one of the indicia is embossed on the outer surface of the container.

38. The system of claim 35, wherein at least one of the indicia is molded on the outer surface of the container.

39. The system of claim 35, wherein the transparent window allows at least two of the first, second, or third indicia to be visible through the transparent window.

40. The system of claim 35, wherein at least one of the indicia is a machine readable indicia.

41. The system of claim 35, wherein at least one of the indicia is a bar code.

42. The system of claim 35, wherein at least one of the indicia is a quick response code.

43. The system of claim 40, further comprising an electronic device wherein the machine readable indicia is configured to cause the electronic device to execute a function when the machine readable indicia is scanned by the electronic device.

* * * * *